

**BHARAT HEAVY ELECTRICALS LIMITED**

INDUSTRIAL VALVES PLANT  
433, INDUSTRIAL COMPLEX  
GOINDWAL SAHIB  
DISTT. TARN TARAN- PUNJAB  
SUB-CONTRACTING DEPT

No.  
BHE:IVP:SC:EOI:FDN:  
2025-26/01-DATED  
04.11.2025

**NOTICE INVITING EXPRESSION OF INTEREST (EOI) FOR  
FABRICATION/MANUFACTURING OF FOUNDATION BOLTS**

BHARAT HEAVY ELECTRICALS LIMITED [BHEL] is manufacturing Industrial Valves and other Boiler accessories at its Industrial Valves Plant [IVP], Goindwal Sahib unit.

Expression of interest is invited from Manufacturers/Fabricators\* for "**FABRICATION/MANUFACTURING OF FOUNDATION BOLTS**" on job work basis.

The interested parties should have inhouse facilities for Turning, Threading, Welding, Grinding, Cleaning/deburring, Material handling etc. as per technical requirements of drawings. Raw material including nut and washers will be provided by BHEL and consumables have to be arranged by vendors. The sample drawings are enclosed for reference.

(\*BHEL encourages procurement from Micro and Small Enterprises i.e. MSEs).

Interested parties shall furnish the required EOI by **1700 Hrs. on or before 15.11.2025**. The EOI can be submitted to following executives via email/courier/by hand: -

For any clarifications, interested vendors may visit our plant on any working day from Monday to Saturday between 0900 Hrs to 1730 Hrs and contact following persons:

**Contact Details**

Sh. Simran Singh Dy. Manager (Sub-Cont) Bharat Heavy Electricals Limited Industrial Valves Plant, Goindwal, Taran tarn, Punjab-143422	Sh. Gopal Singh DGM (Sub-Cont) Bharat Heavy Electricals Limited Industrial Valves Plant, Goindwal, Taran tarn, Punjab-143422
01859-224626	01859-224669
8130839771	9410395245
<a href="mailto:simran@bhel.in">simran@bhel.in</a>	<a href="mailto:gopals@bhel.in">gopals@bhel.in</a>

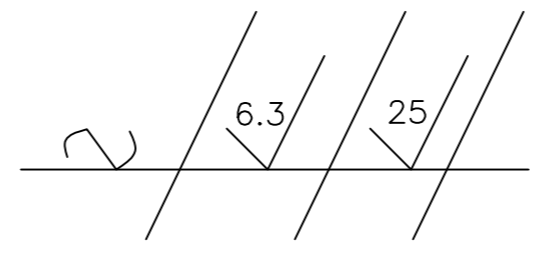
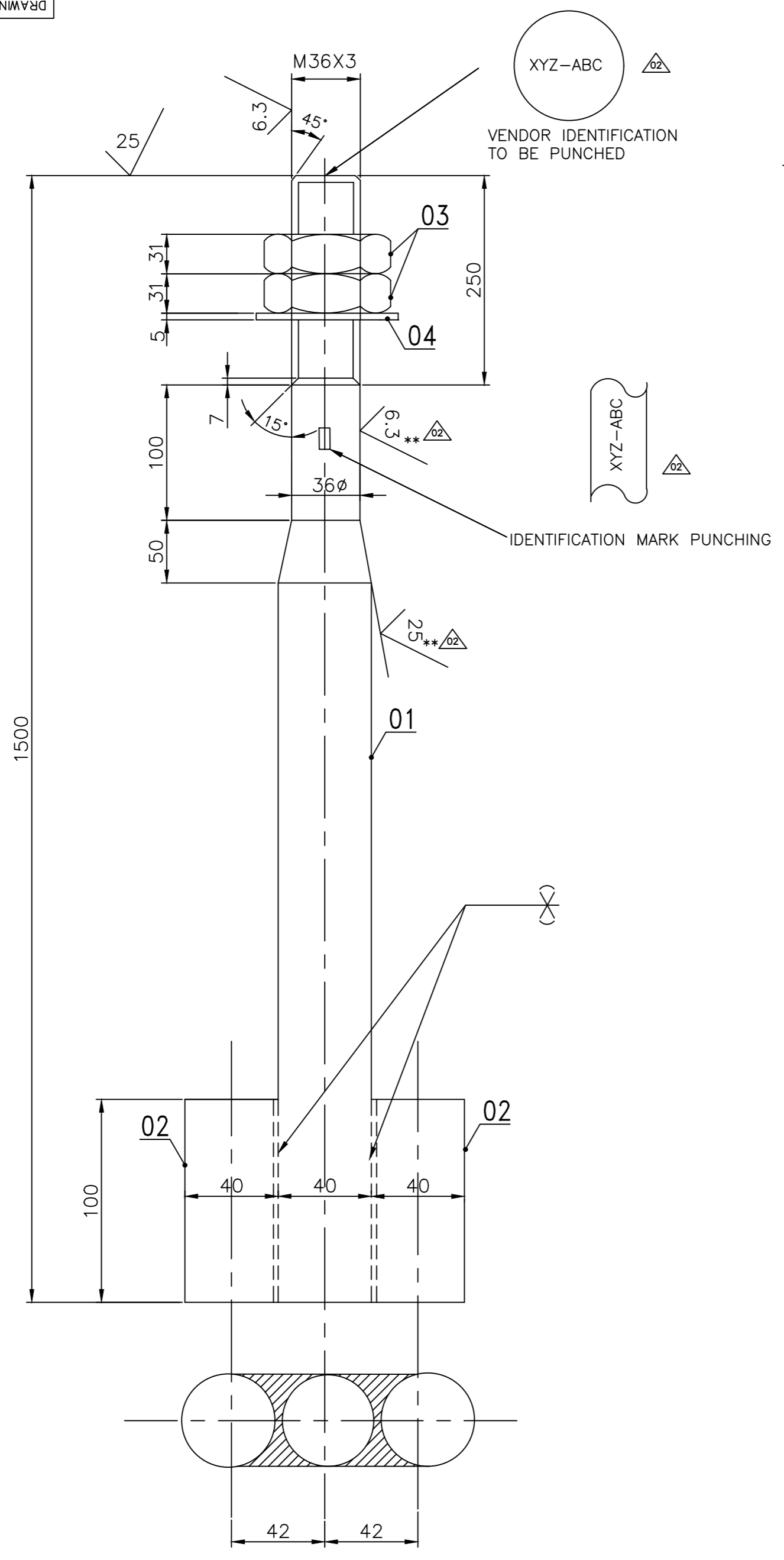

SIZE AND TYPE OF WELD	TYPE OF ELECTRODE	TOTAL LENGTH OF WELD IN MTRS
$\infty$ $\triangle$	E 7018	0.400

$\triangle$  COMPONENT MATERIAL CODE - 942490514640

**NOTES :-**

- 01) FOUNDATION BOLT SHOULD NOT BE PAINTED.
- 02) THREAD ENDS OF BOLT TO BE COATED WITH RUST PROOF OIL AND PROTECTED AGAINST CORROSION .
- 03) MANUFACTURING REQUIRMENTS SHALL BE AS PER SQP NP 28/00 (LATEST REVISION).
- 04) MATERIALS AND OTHERS REQUIRMENTS ARE GIVEN PER ASSEMBLY ONLY.
- $\triangle$ \*\*05) DIAMETER REDUCTION (TAPERING AND REDUCED SHANK) IS TO BE BY MACHINING ONLY.
- $\triangle$  06) LOAD TEST REQUIREMENT - BOLT SHALL WITHSTAND MINIMUM TENSILE LOAD OF 12 MT.

VARIANT NUMBER	ITEM NUMBER	DESCRIPTION	STD	DRAWING NUMBER	ITEM NO	MATERIAL CODE	A/C/P	UNIT	UNIT WEIGHT	CS	ZONE
VAR NO	MATERIAL SPECN	QUANTITY					DI				
	04	WASHER PUNCHD; A36				41408-00036			0.087		
								1			
	03	NUT HEX GR.C M36X3				41304-00036			0.396		
								2			
	02	ROD DIA 40; 100				15-339-141 SA105			0.985		
								2			
	01	ROD DIA 40: 1500				15-339-141 SA105			14.774		
								1			

REV 02	DATE 01.08.2025	ALTERED MENAGA/YUVARAJ
ZONE $\triangle$	COMP MCODE ADDED, NOTE 5&6 ADDED ITEM:1&2 MAT. SPEC CHANGED BASED ON RCA APL/25/01 RECOMMENDATION.	
REV 01	DATE 08.02.99	ALTERED : M.B.K.RAJA
ZONE $\triangle$	WELDING DETAIL ALTERED	

CAUTION: The information on this document is the property of BHARAT HEAVY ELECTRICALS LTD. It must not be used directly or indirectly in any way detrimental to the interest of the company.

TYPE OF PRODUCT OR NAME OF CUSTOMER/PROJECT						
	Bharat Heavy Electricals Ltd		DRN	NAME	SIGNATURE	DATE
	UNIT: HIGH PRESSURE BOILER PLANT		CHD	M.B.K.RAJA		23.04.98
	TIRUCHIRAPALLI - 620014		APPD	R.M.A		26.04.98
DEPT ST	ALL DIMENSIONS ARE IN MM	PROJECTION	SCALE	WEIGHT (Kg)	REF TO ASSY / OLD DWG	
CODE 122		$\triangle$	N.T.S			
TITLE				DRAWING NO :		REV
FOUNDATION BOLT				2-35-010-01246		02
40 DIA -1500 LONG						

DRAWING NO. 2-35-010-01247

FOR TOLERANCES OF UNTOLERANCED DIMENSIONS DURING MANUFACTURE REFER PLANT STD. NO TP 023 0299

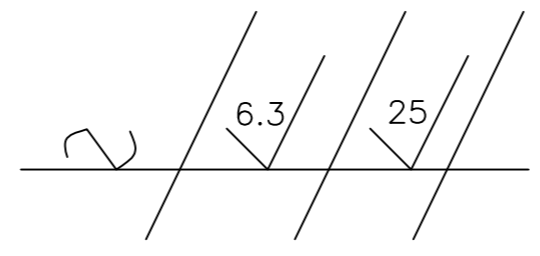
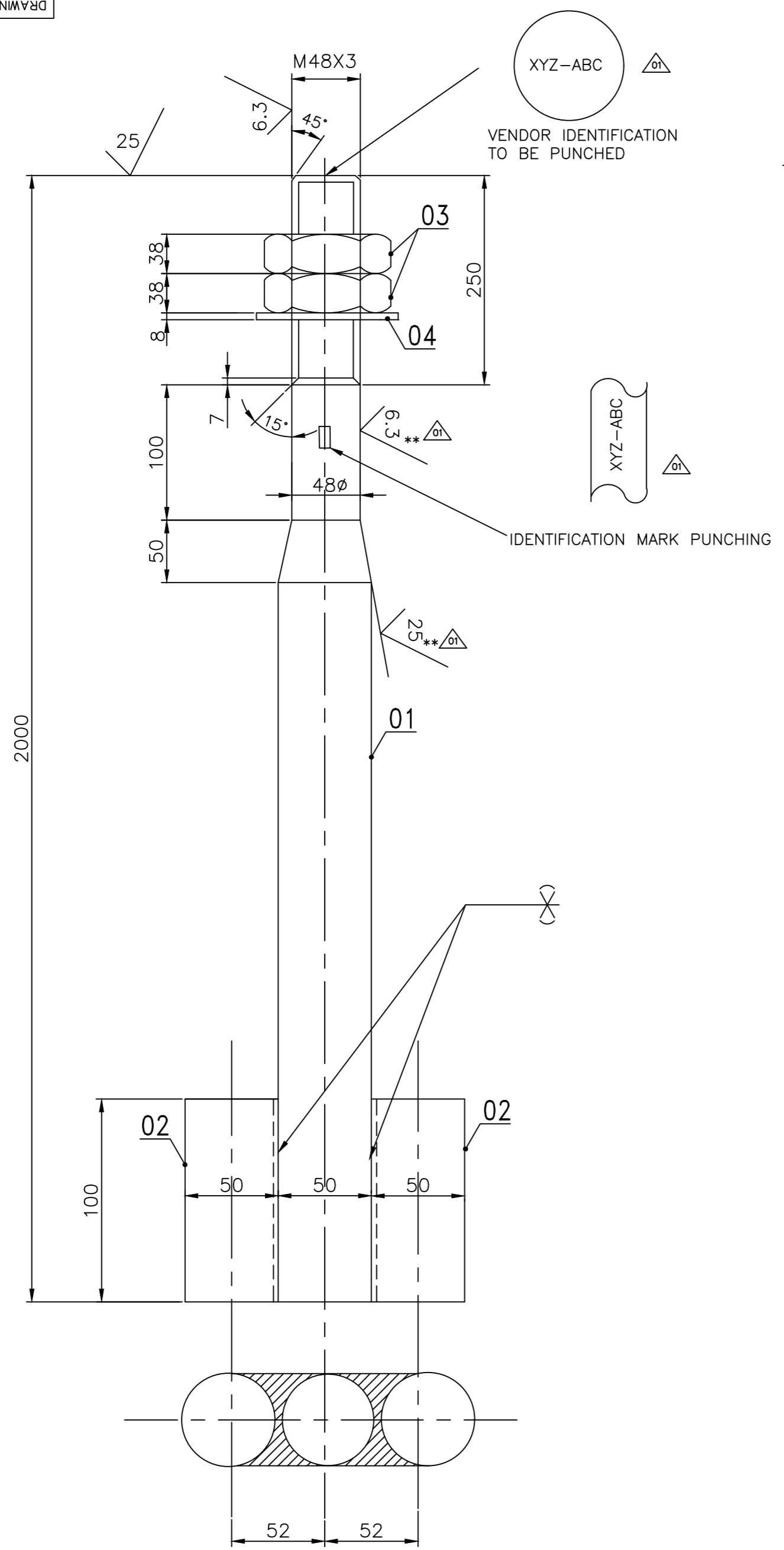

SIZE AND TYPE OF WELD	TYPE OF ELECTRODE	TOTAL LENGTH OF WELD IN MTRS
12 $\infty$	E 7018	0.400

COMPONENT MATERIAL CODE - 942490524750

NOTES :-

- 01) FOUNDATION BOLT SHOULD NOT BE PAINTED.
- 02) THREAD ENDS OF BOLT TO BE COATED WITH RUST PROOF OIL AND PROTECTED AGAINST CORROSION .
- 03) MANUFACTURING REQUIRMENTS SHALL BE AS PER SQP NP 28/00 (LATEST REVISION).
- 04) MATERIALS AND OTHERS REQUIRMENTS ARE GIVEN PER ASSEMBLY ONLY.
- 05) DIAMETER REDUCTION (TAPERING AND REDUCED SHANK) IS TO BE BY MACHINING ONLY.
- 06) LOAD TEST REQUIREMENT - BOLT SHALL WITHSTAND MINIMUM TENSILE LOAD OF 22 MT.

VARIANT NUMBER	ITEM NUMBER	DESCRIPTION	STD	DRAWING NUMBER	ITEM NO	MATERIAL CODE	A/C/P	UNIT	UNIT WEIGHT	CS	ZONE
VAR NO	MATERIAL SPECN	QUANTITY					DI				
	04	WASHER PUNCHD; A48				41408-00048			0.284		
	03	NUT HEX GR.C M48X3				41304-00048			0.928		
	02	ROD DIA 50; 100				15-339-142 SA105			1.540		
	01	ROD DIA 50: 2000				15-339-142 SA105			30.800		

F

REV 01	DATE 01.08.2025	ALTERED :MENAGA/YUVARAJ
ZONE	CHD & APPD : VSRK	
	ITEM:1&2 MAT. SPEC CHANGED BASED ON RCA APL/25/01 RECOMMENDATION.	

CAUTION: The information on this document is the property of BHARAT HEAVY ELECTRICALS LTD. It must not be used directly or indirectly in any way detrimental to the interest of the company.

TYPE OF PRODUCT OR NAME OF CUSTOMER/PROJECT

**Bharat Heavy Electricals Ltd**  
UNIT: HIGH PRESSURE BOILER PLANT  
TIRUCHIRAPALLI - 620014

DRN	NAME AMALA.M	SIGNATURE	DATE 23.04.98
CHD	M.B.K.RAJA		26.04.98
APPD	R.M.A		26.04..98

DEPT ST ALL DIMENSIONS ARE IN MM PROJECTION SCALE N.T.S WEIGHT (Kg) REF TO ASSY / OLD DWG

CODE 122

TITLE **FOUNDATION BOLT 50 DIA -2000 LONG** DRAWING NO : 2-35-010-01247 REV 01

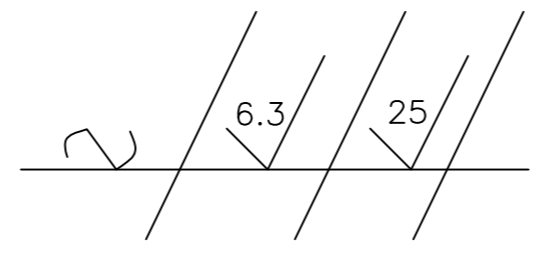
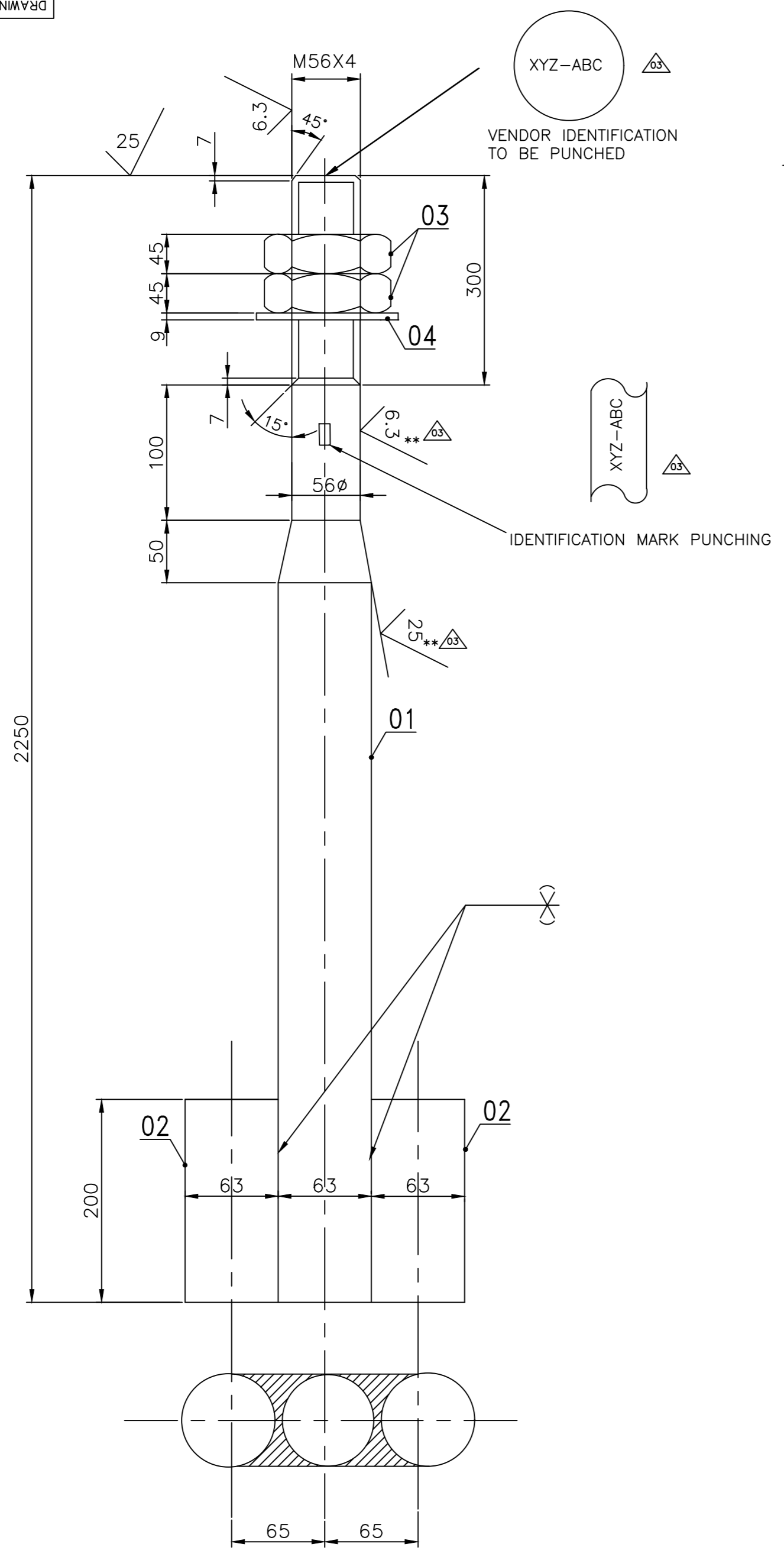

SIZE AND TYPE OF WELD	TYPE OF ELECTRODE	TOTAL LENGTH OF WELD IN MTRS
∞ △	E 7018	0.800

△ COMPONENT MATERIAL CODE - 942490534963

**NOTES :-**

- 01) FOUNDATION BOLT SHOULD NOT BE PAINTED.
- 02) THREAD ENDS OF BOLT TO BE COATED WITH RUST PROOF OIL AND PROTECTED AGAINST CORROSION .
- 03) MANUFACTURING REQUIRMENTS SHALL BE AS PER SQP NP 28/00 (LATEST REVISION).
- 04) MATERIALS AND OTHERS REQUIRMENTS ARE GIVEN PER ASSEMBLY ONLY.
- △\*\*05) DIAMETER REDUCTION (TAPERING AND REDUCED SHANK) IS TO BE BY MACHINING ONLY.
- △ 06) LOAD TEST REQUIREMENT - BOLT SHALL WITHSTAND MINIMUM TENSILE LOAD OF 30 MT.

VARIANT NUMBER	ITEM NUMBER	DESCRIPTION	STD	DRAWING NUMBER	ITEM NO	MATERIAL CODE	A/C/P	UNIT	UNIT WEIGHT	CS	ZONE
VAR NO	MATERIAL SPECN	QUANTITY					DI				
	04	WASHER PUNCHD A56				41408-000566			0.405		
									1		
	03	NUT HEX GR.C M56X4				41304-00056			1.355		
									2		
	02	ROD DIA 63 200				15-339-143 SA105			4.900		
									2		
	01	ROD DIA 63; 2250				15-339-143 SA105			55.125		
									1		

REV 03	DATE 01.08.2025	ALTERED MENAGA/YUVARAJ CHD & APPD : VSRK
ZONE	COMP MCODE ADDED, NOTE 5&6 ADDED ITEM:1&2 MAT. SPEC CHANGED BASED ON RCA APL/25/01 RECOMMENDATION.	
REV 02	DATE 08.10.07	ALTERED : C. SURESH CHD & APPD : D.V.N
ZONE	BOLT MANUFACTURING PROCESS UPDATED	
REV 01	DATE 08.02.99	ALTERED : S.A.BABU CHD & APPD P.RAVINDRAN
ZONE	WELDING DETAIL ALTERED	

TYPE OF PRODUCT OR NAME OF CUSTOMER/PROJECT

**Bharat Heavy Electricals Ltd**  
UNIT: HIGH PRESSURE BOILER PLANT  
TIRUCHIRAPALLI - 620014

DRN	NAME S.A.BABU	SIGNATURE	DATE 27.04.98
CHD	P.RAVINDRAN		26.11.98
APPD	R.JEYAKUMAR		27.11.98

DEPT ST ALL DIMENSIONS ARE IN MM PROJECTION SCALE N.T.S WEIGHT (Kg) REF TO ASSY / OLD DWG

CODE 122

TITLE **FOUNDATION BOLT**  
**63 DIA - 2250 LONG**

DRAWING NO : 2-35-010-01249 03 REV

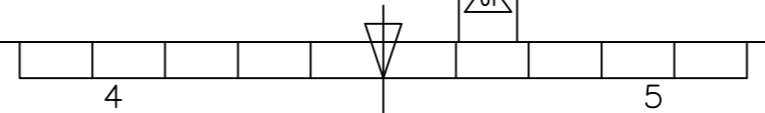

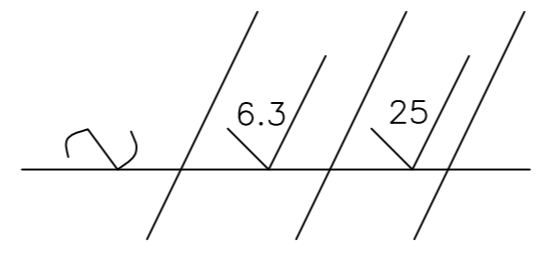
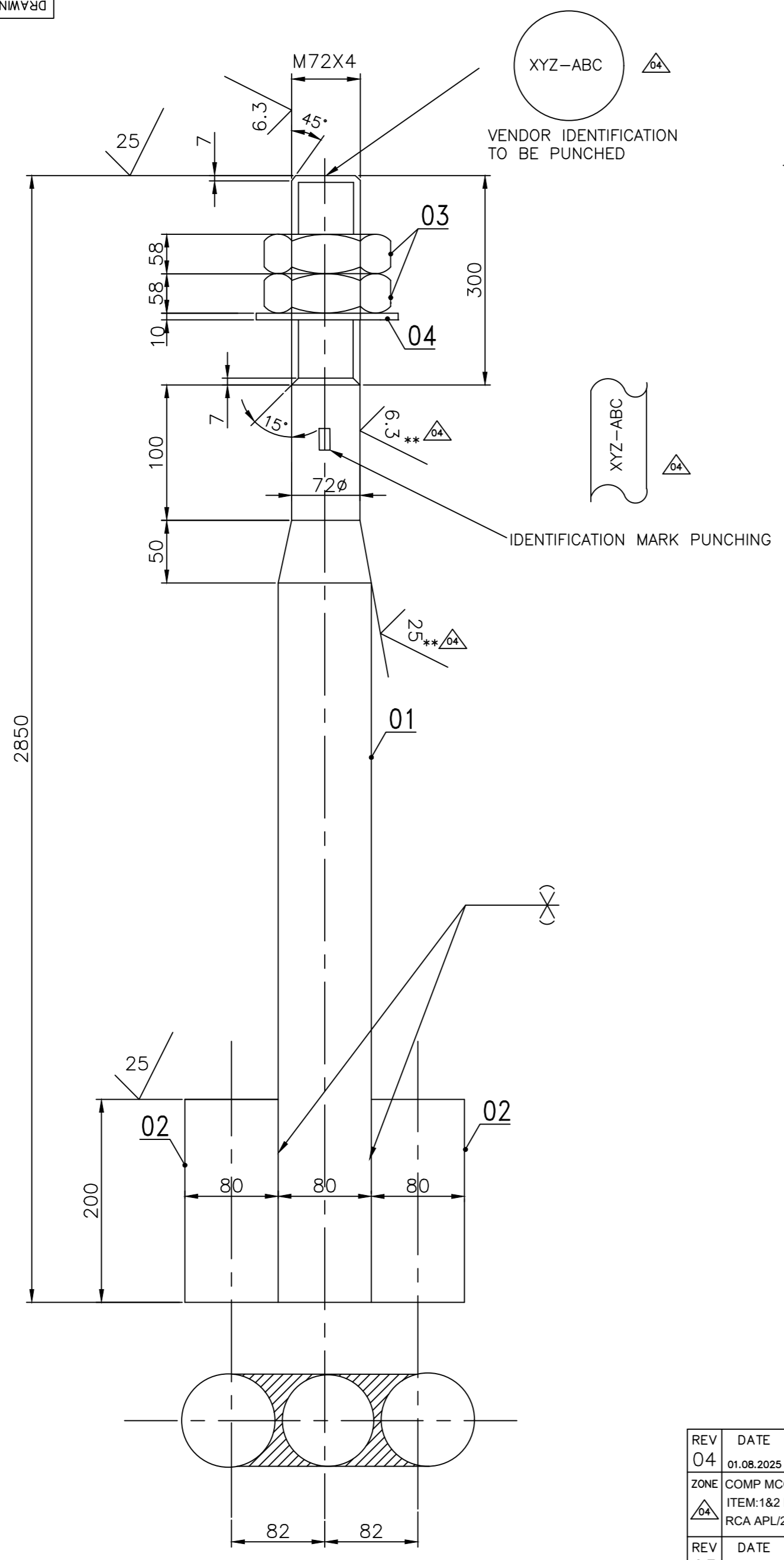

SIZE AND TYPE OF WELD	TYPE OF ELECTRODE	TOTAL LENGTH OF WELD IN MTRS
∞	E 7018	0.800

COMPONENT MATERIAL CODE - 942490010000

NOTES :-

- 01) FOUNDATION BOLT SHOULD NOT BE PAINTED.
- 02) THREAD ENDS OF BOLT TO BE COATED WITH RUST PROOF OIL AND PROTECTED AGAINST CORROSION .
- 03) MANUFACTURING REQUIRMENTS SHALL BE AS PER SQP NP 28/00 (LATEST REVISION).
- 04) MATERIALS AND OTHERS REQUIRMENTS ARE GIVEN PER ASSEMBLY ONLY.
- 04\*\*05) DIAMETER REDUCTION (TAPERING AND REDUCED SHANK) IS TO BE BY MACHINING ONLY.
- 04) 06) LOAD TEST REQUIREMENT - BOLT SHALL WITHSTAND MINIMUM TENSILE LOAD OF 52 MT

VARIANT NUMBER	ITEM NUMBER	DESCRIPTION	STD	DRAWING NUMBER	ITEM NO	MATERIAL CODE	A/C/P	UNIT	UNIT WEIGHT	CS	ZONE
VAR NO	MATERIAL SPECN	DI	QUANTITY								
	04	WASHER PUNCHD; A72				4140800072			0.543		
	03	NUT HEX GR.B M72X4				4130440072			2.430		
	02	ROD DIA 80; 200				15-339-144 SA105			7.900		
	01	ROD DIA 80; 2850				15-339-144 SA105			112.575		

REV	DATE	ALTERED	BY	ZONE	REV	DATE	ALTERED	BY	ZONE
04	01.08.2025	CHD & APPD : VSRK		E7	02	24.08.23	CHD & APPD : RAJIV		E7
03	12.12.24	CHD & APPD : Praveen/AGN		E7	01	01.12.21	CHD & APPD : S.MUTHU		E7

NOTES ADDED

TYPE OF PRODUCT OR NAME OF CUSTOMER/PROJECT

Bharat Heavy Electricals Ltd  
UNIT: HIGH PRESSURE BOILER PLANT  
TIRUCHIRAPALLI - 620014

DRN	K.S.PANDIAN	SIGNATURE	DATE
CHD	G.R.D		07.10.09
APPD	D.V.N		07.10.09

DEPT ST ALL DIMENSIONS ARE IN MM PROJECTION SCALE N.T.S WEIGHT (Kg) REF TO ASSY / OLD DWG

TITLE FOUNDATION BOLT 80 DIA -2850 LONG DRAWING NO : 2-35-010-06210 REV 04

08010-010-01080  
DRAWING NO.

FOR TOLERANCES OF UNTOLERANCED DIMENSIONS DURING MANUFACTURE REFER PLANT STD. NO TP 023 0299

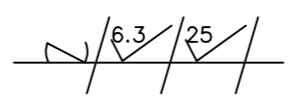
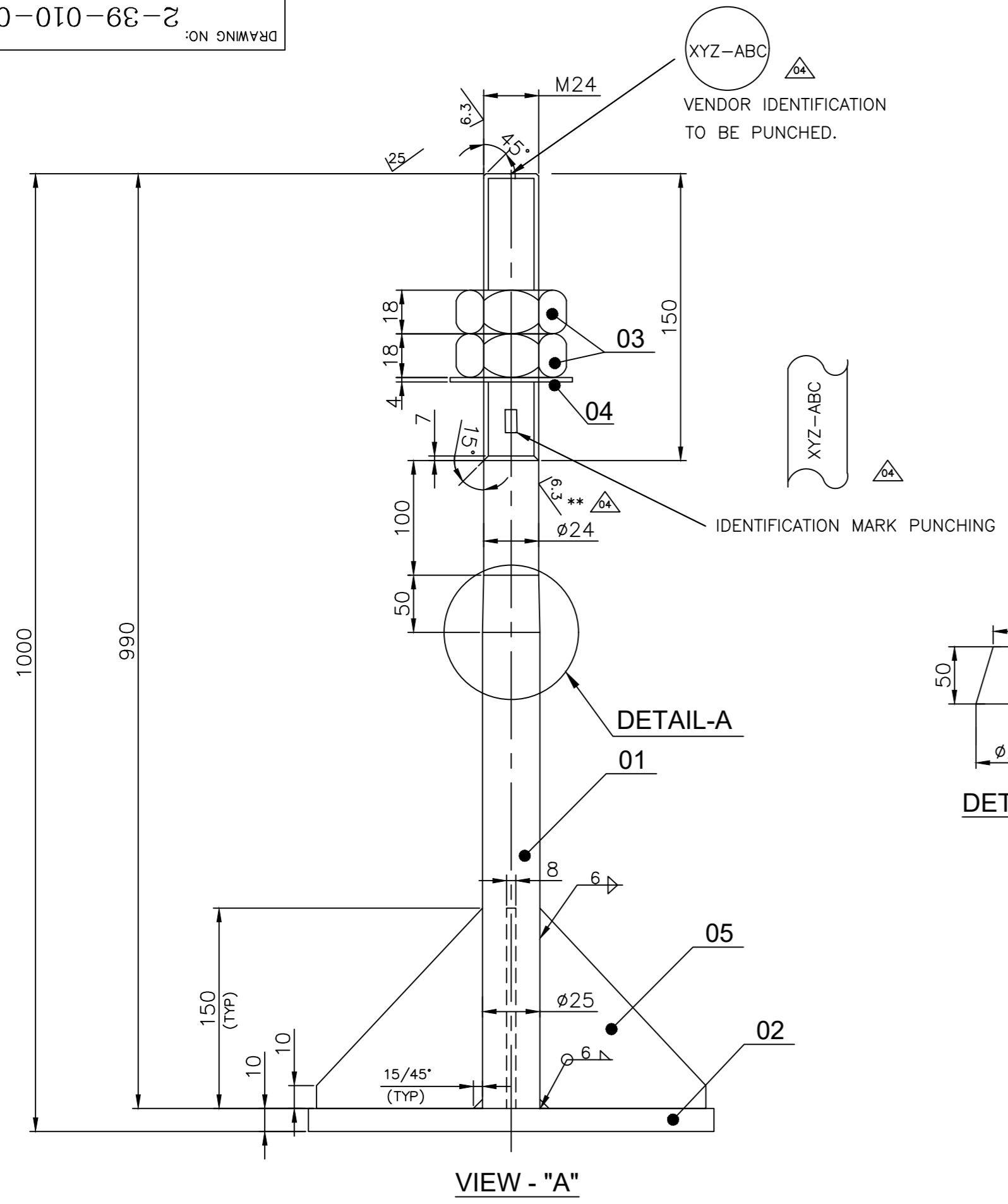

SIZE AND TYPE OF WELD	TYPE OF ELECTRODE	TOTAL LENGTH OF WELD IN MTRS.
6 FILLET	E7018	2.280

COMPONENT MATERIAL CODE - 942490548025

**NOTES: -**

- 01. FOUNDATION BOLT SHOULD NOT BE PAINTED.
- 02. THREAD ENDS OF BOLT TO BE COATED WITH RUST PROOF OIL AND PROTECTED AGAINST CORROSION.
- 03. MANUFACTURING REQUIREMENTS SHALL BE AS PER SQP NP 28/00 (LATEST REVISION).
- 04. MATERIALS AND OTHER REQUIREMENTS ARE GIVEN PER BOILER ONLY.
- 05. DIAMETER REDUCTION (TAPERING AND REDUCED SHANK) IS TO BE BY MACHINING ONLY.
- 06. LOAD TEST REQUIREMENT - BOLT SHALL WITHSTAND MINIMUM TENSILE LOAD OF 5 MT

VARIANT NUMBER	ITEM NUMBER	DESCRIPTION	STD	DRAWING NUMBER	ITEM NO	MATERIAL CODE	A/C/P	UNIT	UNIT WEIGHT	CS	ZONE
					VAR NO	MATERIAL SPECN					
	05	PL 150X85X8				15011027			0.427		
						IS2062Fe410A			4		
	04	WASHER PUNCHD.A24				41408-00024			0.031		
						IS2016-A			1		
	03	NUT HEX Gr C M24				41304-00024			0.110		
						IS1363P3-CL4			2		
	02	PL 150X150X10				15211098			1.766		
						IS2062Fe410A			1		
	01	ROD DIA 25; 990				15-339-139			3.814		
						SA105			1		

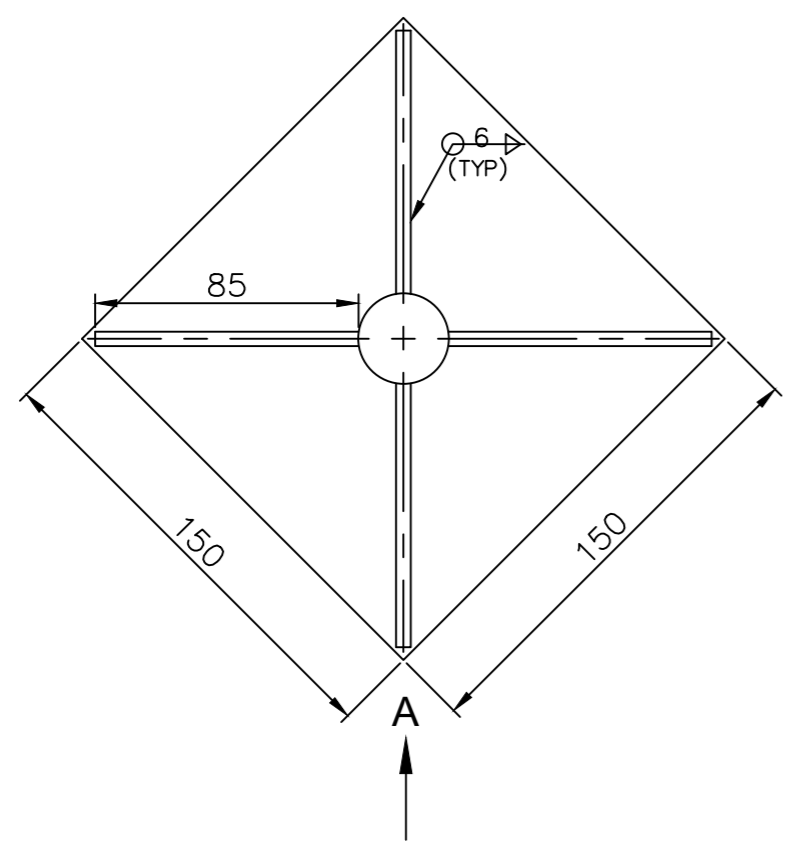

REV	DATE	ALTERED	BY	REV	DATE	ALTERED	BY
04	01.08.2025	CHD & APPD : VSRK	MENAGA/YUVARAJ	03	24.08.23	CHD & APPD : RAJIV	MPN
02	27.04.17	CHD & APPD : SOMU.J	MUTHU/SKP	01	22.12.16	CHD & APPD : SOMU.J	MUTHU/SKP

CAUTION: The information on this document is the property of BHARAT HEAVY ELECTRICALS LTD. It must not be used directly or indirectly in any way detrimental to the interest of the company.

TYPE OF PRODUCT OR NAME OF CUSTOMER/PROJECT

Bharat Heavy Electricals Ltd  
UNIT: HIGH PRESSURE BOILER PLANT  
TIRUCHIRAPALLI - 620014

DRN	NAME	SIGNATURE	DATE
CHD	S.JOHN		21.04.98
APPD	MBKRAJA		22.04.98
	R.JEYAKUMAR		22.04.98

DEPT: ST  
CODE: 122

ALL DIMENSIONS ARE IN MM

PROJECTION:

SCALE: N.T.S

WEIGHT (Kg): 2-35-010-01223

REF TO ASSY / OLD DWG: 2-35-010-01223

TITLE: FOUNDATION BOLT 25 DIA. 1000 LONG

DRAWING NO: 2-39-010-01080

REV: 04

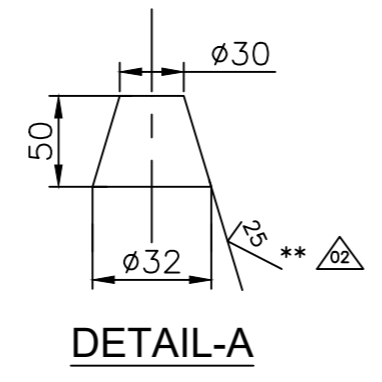
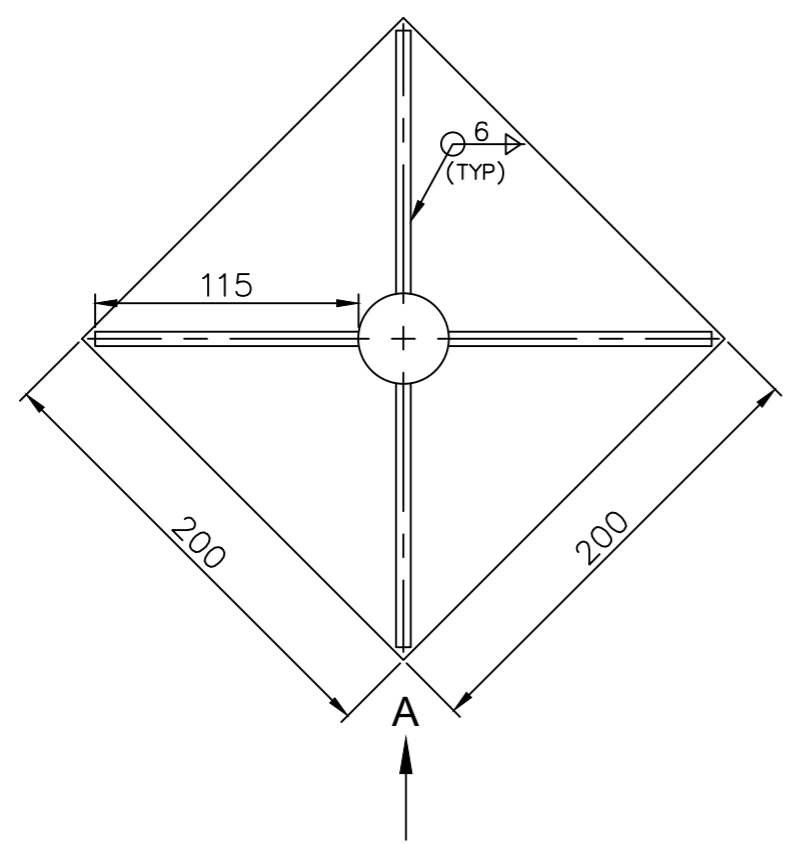
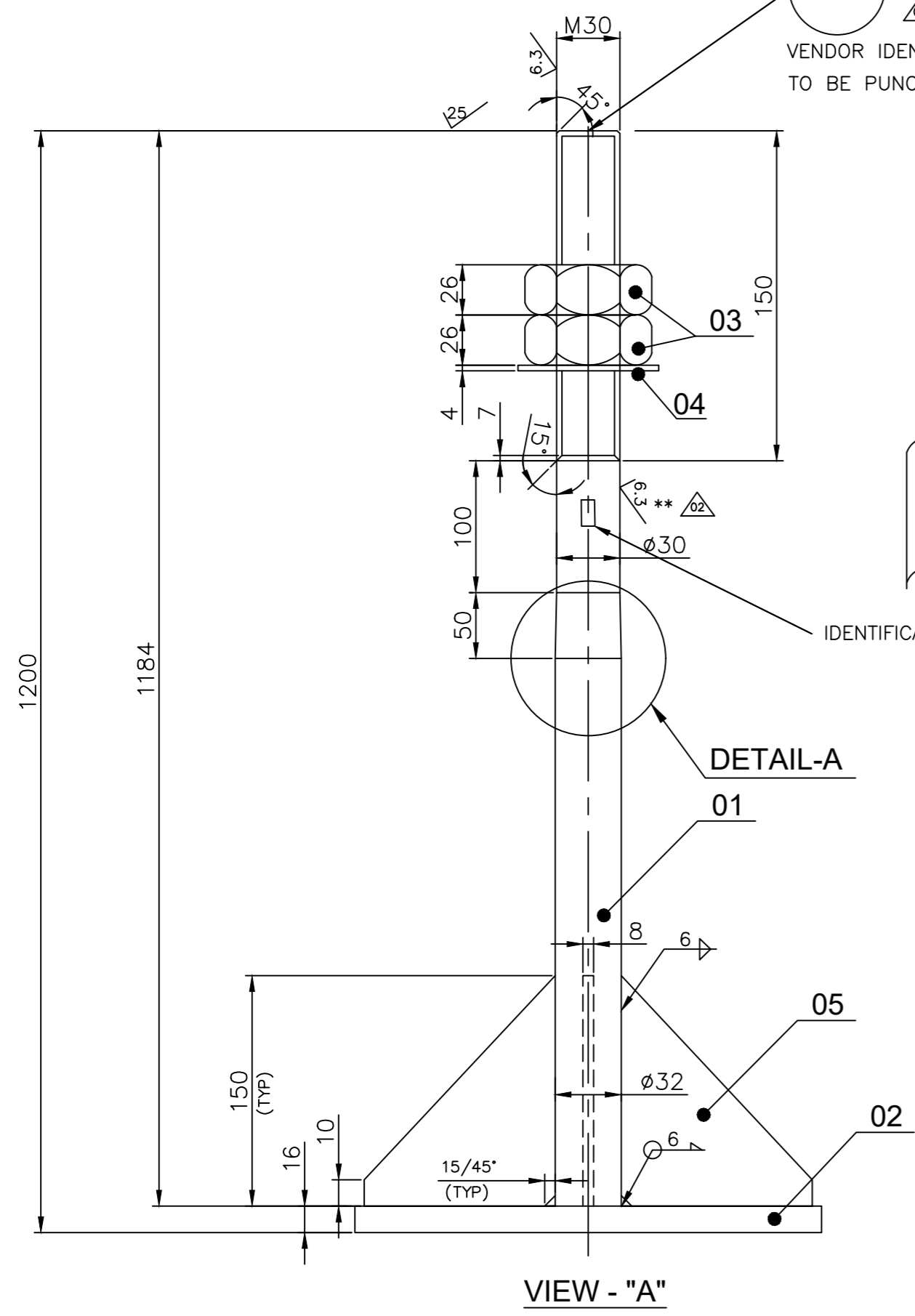

6.3/25

SIZE AND TYPE OF WELD	TYPE OF ELECTRODE	TOTAL LENGTH OF WELD IN MTRS.
6 FILLET	E7018	2.260

COMPONENT MATERIAL CODE - 942490558132

**NOTES: -**

- 01. FOUNDATION BOLT SHOULD NOT BE PAINTED.
- 02. THREAD ENDS OF BOLT TO BE COATED WITH RUST PROOF OIL AND PROTECTED AGAINST CORROSION.
- 03. MANUFACTURING REQUIREMENTS SHALL BE AS PER SQP NP 28/00 (LATEST REVISION).
- 04. MATERIALS AND OTHER REQUIREMENTS ARE GIVEN PER BOILER ONLY.
- 05. DIAMETER REDUCTION (TAPERING AND REDUCED SHANK) IS TO BE BY MACHINING ONLY.
- 06. LOAD TEST REQUIREMENT - BOLT SHALL WITHSTAND MINIMUM TENSILE LOAD OF 8 MT.

VARIANT NUMBER	ITEM NUMBER	DESCRIPTION	STD	DRAWING NUMBER	ITEM NO	MATERIAL CODE	A/C/P	UNIT	UNIT WEIGHT	CS	ZONE
					VAR NO	MATERIAL SPECN		DI	QUANTITY		
	05	PL 150X115X8				15011027			0.577		
						IS2062Fe410A			4		
	04	WASHER PUNCHD.A30				41408-00030			0.050		
									1		
	03	NUT HEX Gr C M30				41304-00030			0.231		
									2		
	02	PL 200X200X16				15011026			5.024		
						IS2062Fe410A			1		
	01	ROD DIA 32; 1184				15-339-140			7.475		
						SA105			1		

REV	DATE	ALTERED	BY
02	01.08.2025	CHD & APPD	VSRK
01	02.06.2025	CHD & APPD	VSRK

CAUTION: The information on this document is the property of BHARAT HEAVY ELECTRICALS LTD. It must not be used directly or indirectly in any way detrimental to the interest of the company.

TYPE OF PRODUCT OR NAME OF CUSTOMER/PROJECT

Bharat Heavy Electricals Ltd  
UNIT: HIGH PRESSURE BOILER PLANT  
TIRUCHIRAPALLI - 620014

DRN	NAME	SIGNATURE	DATE
CHD	S.JOHN		21.04.98
APPD	R.JEYAKUMAR		22.04.98

DEPT: ST  
CODE: 122

ALL DIMENSIONS ARE IN MM

PROJECTION: SCALE: N.T.S

WEIGHT (Kg): 2-35-010-01224

REF TO ASSY / OLD DWG: 2-35-010-01224

TITLE: FOUNDATION BOLT 32 DIA. 1200 LONG

DRAWING NO: 2-39-010-01081

REV: 02

DRAWING NO. 2-39-010-01082

FOR TOLERANCES OF UNTOLERANCED DIMENSIONS DURING MANUFACTURE REFER PLANT STD. NO TP 023 0299

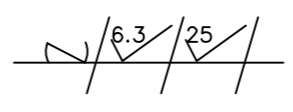
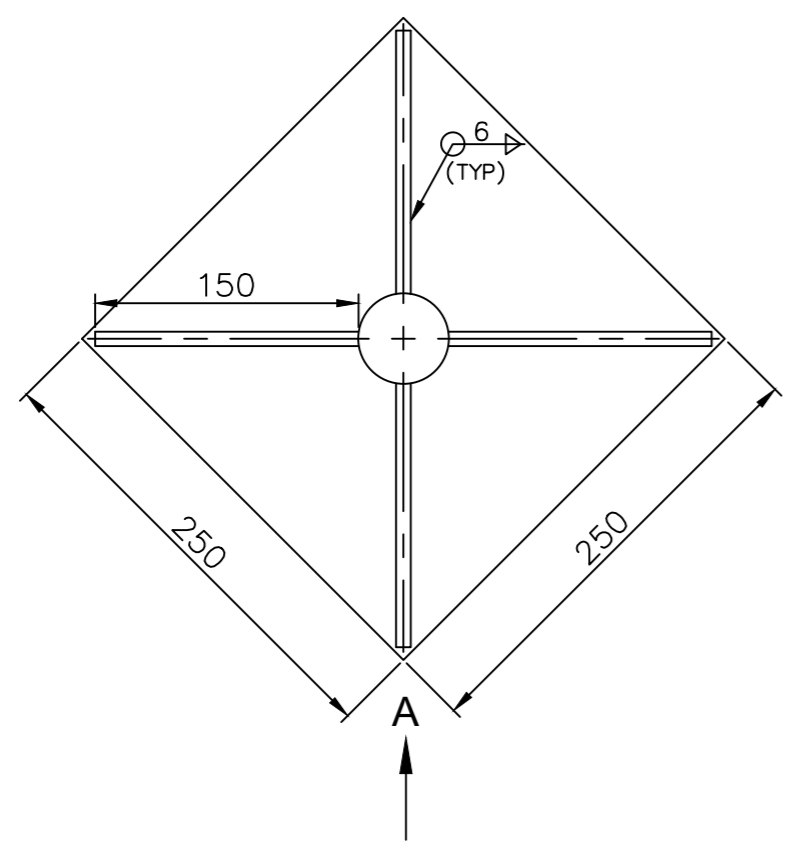
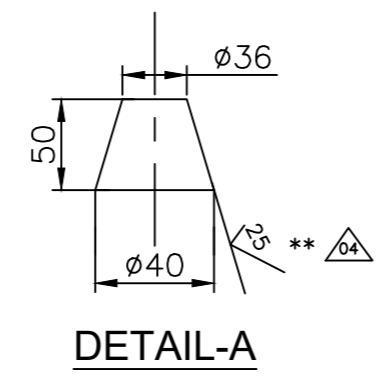
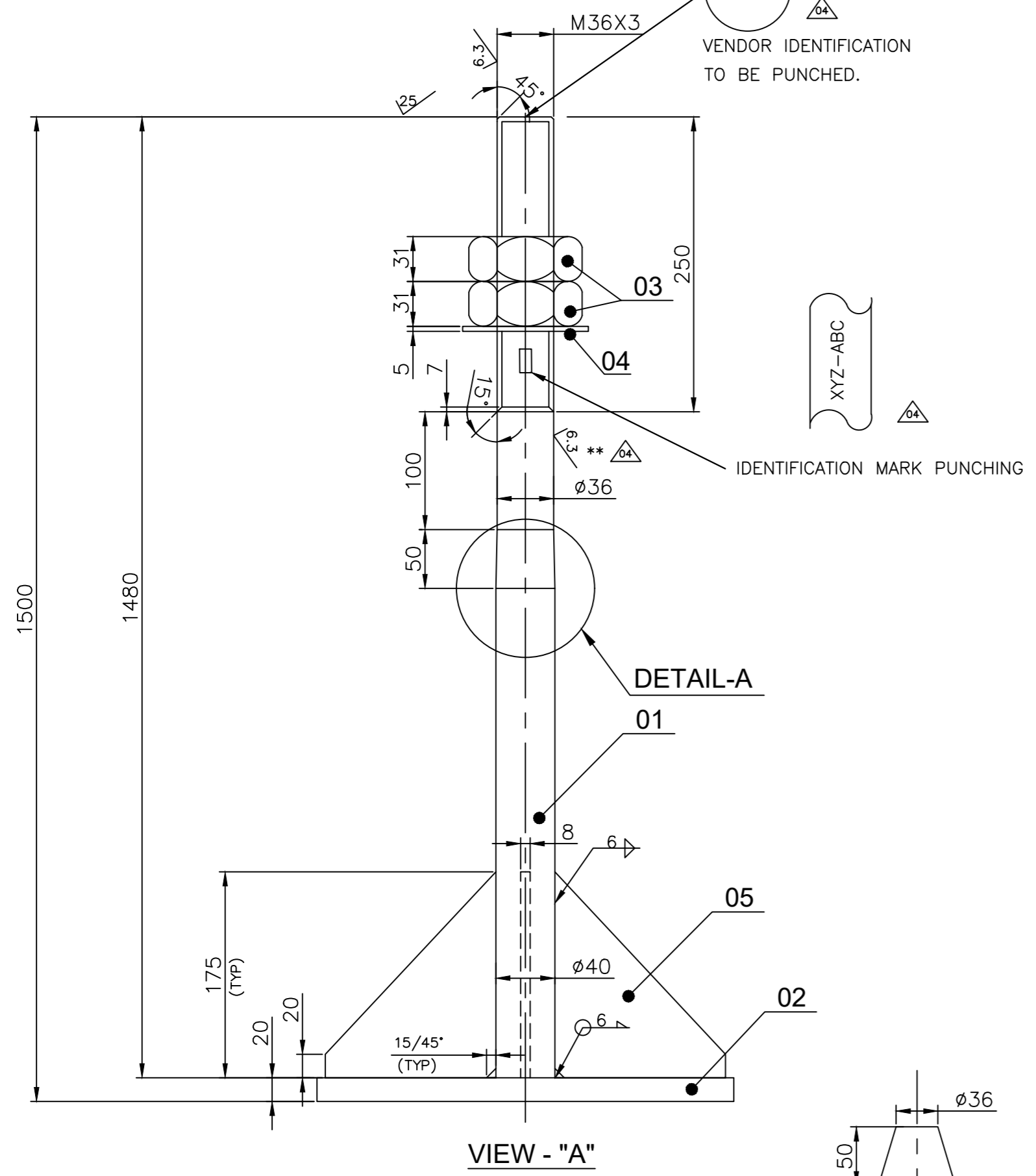

SIZE AND TYPE OF WELD	TYPE OF ELECTRODE	TOTAL LENGTH OF WELD IN MTRS.
6 FILLET	E7018	2.280

COMPONENT MATERIAL CODE - 942490568240

NOTES: -

- 01. FOUNDATION BOLT SHOULD NOT BE PAINTED.
- 02. THREAD ENDS OF BOLT TO BE COATED WITH RUST PROOF OIL AND PROTECTED AGAINST CORROSION.
- 03. MANUFACTURING REQUIREMENTS SHALL BE AS PER SQP NP 28/00 (LATEST REVISION).
- 04. MATERIALS AND OTHER REQUIREMENTS ARE GIVEN PER BOILER ONLY.
- 05. DIAMETER REDUCTION (TAPERING AND REDUCED SHANK) IS TO BE BY MACHINING ONLY.
- 06. LOAD TEST REQUIREMENT - BOLT SHALL WITHSTAND MINIMUM TENSILE LOAD OF 12 MT

VARIANT NUMBER	ITEM NUMBER	DESCRIPTION	STD	DRAWING NUMBER	ITEM NO	MATERIAL CODE	A/C/P	UNIT	UNIT WEIGHT	CS	ZONE
VAR NO						MATERIAL SPECN		DI	QUANTITY		
	05	PL 175X150X8				15011027			0.918		
						IS2062Fe410A			4		
	04	WASHER PUNCHD.A39				41408-00036			0.087		
						IS2016-A			1		
	03	NUT HEX Gr C M36X3				41304-10036			0.396		
						IS1363P4-CL6			2		
	02	PL 250X250X20				15011150			9.813		
						IS2062Fe410A			1		
	01	ROD DIA 40; 1480				15-339-141			14.600		
						SA105			1		

REV	DATE	ALTERED	BY	REV	DATE	ALTERED	BY
04	01.08.2025	CHD & APPD	VSRK	03	24.08.23	CHD & APPD	RAJIV
02	27.04.17	CHD & APPD	SOMU.J	01	22.12.16	CHD & APPD	SOMU.J

CAUTION: The information on this document is the property of BHARAT HEAVY ELECTRICALS LTD. It must not be used directly or indirectly in any way detrimental to the interest of the company.

TYPE OF PRODUCT OR NAME OF CUSTOMER/PROJECT

Bharat Heavy Electricals Ltd  
UNIT: HIGH PRESSURE BOILER PLANT  
TIRUCHIRAPALLI - 620014

DRN: S.JOHN  
CHD: MBKRAJA  
APPD: R.JEYAKUMARDATE: 21.04.98  
DATE: 22.04.98  
DATE: 22.04.98

DEPT: ST  
CODE: 122  
ALL DIMENSIONS ARE IN MM  
PROJECTION:   
SCALE: N.T.S  
WEIGHT (Kg): 2-35-010-01225

TITLE: FOUNDATION BOLT  
40 DIA. 1500 LONG

DRAWING NO: 2-39-010-01082  
REV: 04

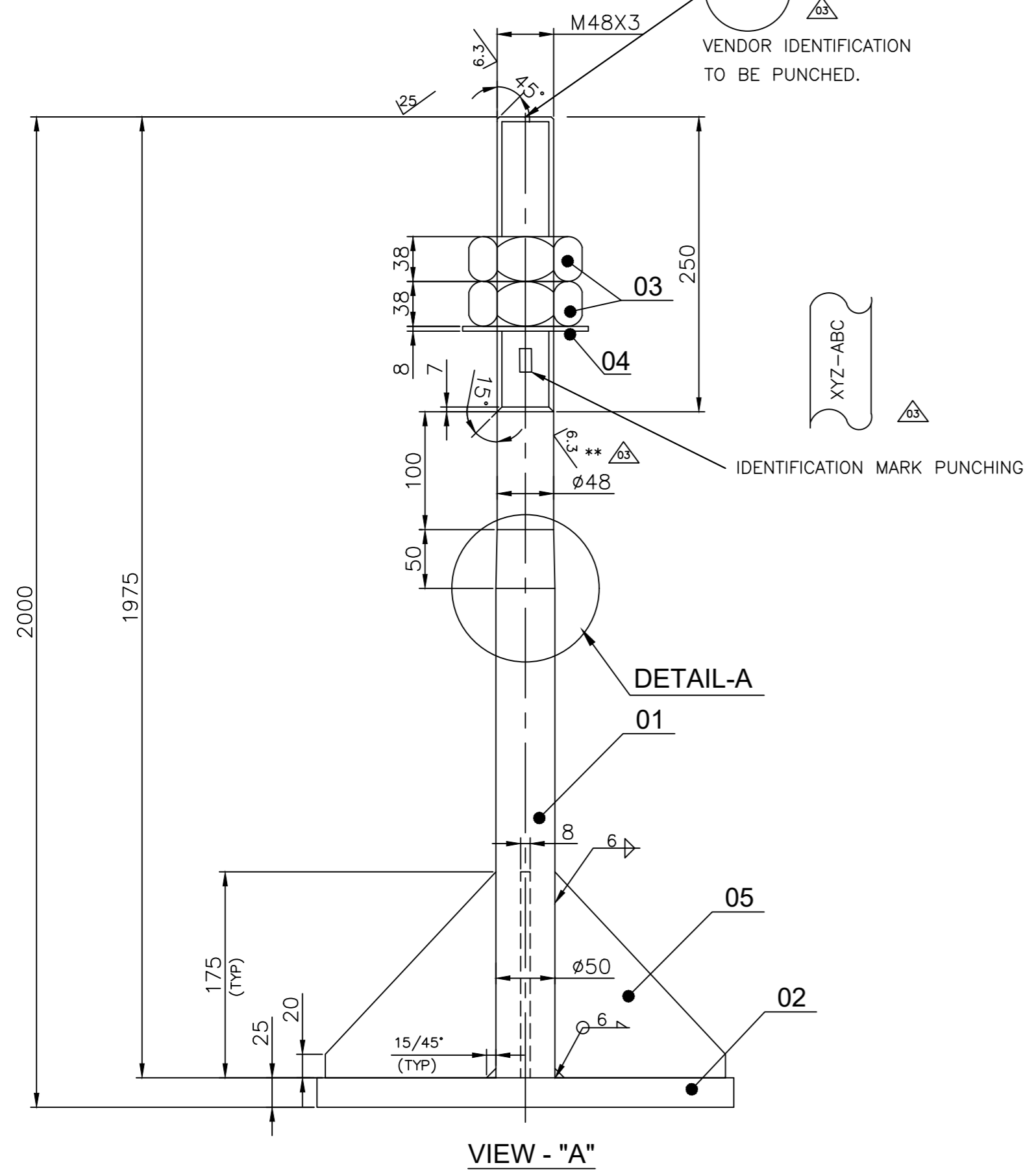

COMPONENT MATERIAL CODE - 942490578350

NOTES: -

- 01. FOUNDATION BOLT SHOULD NOT BE PAINTED.
- 02. THREAD ENDS OF BOLT TO BE COATED WITH RUST PROOF OIL AND PROTECTED AGAINST CORROSION.
- 03. MANUFACTURING REQUIREMENTS SHALL BE AS PER SQP NP 28/00 (LATEST REVISION).
- 04. MATERIALS AND OTHER REQUIREMENTS ARE GIVEN PER BOILER ONLY.
- 05. DIAMETER REDUCTION (TAPERING AND REDUCED SHANK) IS TO BE BY MACHINING ONLY.
- 06. LOAD TEST REQUIREMENT - BOLT SHALL WITHSTAND MINIMUM TENSILE LOAD OF 22 MT

VARIANT NUMBER	ITEM NUMBER	DESCRIPTION	STD	DRAWING NUMBER	ITEM NO	MATERIAL CODE	A/C/P	UNIT	UNIT WEIGHT	CS	ZONE
VAR NO						MATERIAL SPECN		DI	QUANTITY		
	05	PL 175X145X8				15011027			0.888		
						IS2062Fe410A			4		
	04	WASHER PUNCHD.A48				41408-00048			0.284		
						IS2016-A			1		
	03	NUT HEX Gr C M48X3				41304-00048			0.928		
						IS1363P4-CL6			2		
	02	PL 250X250X25				15011081			12.266		
						IS2062Fe410B			1		
	01	ROD DIA 50; 1975				15-339-142			30.441		
						SA105			1		

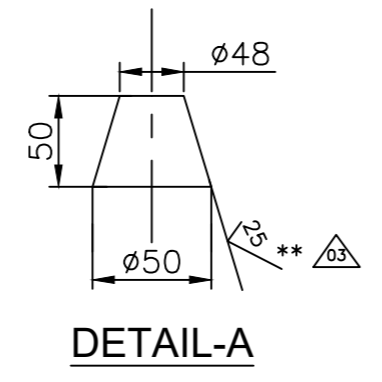
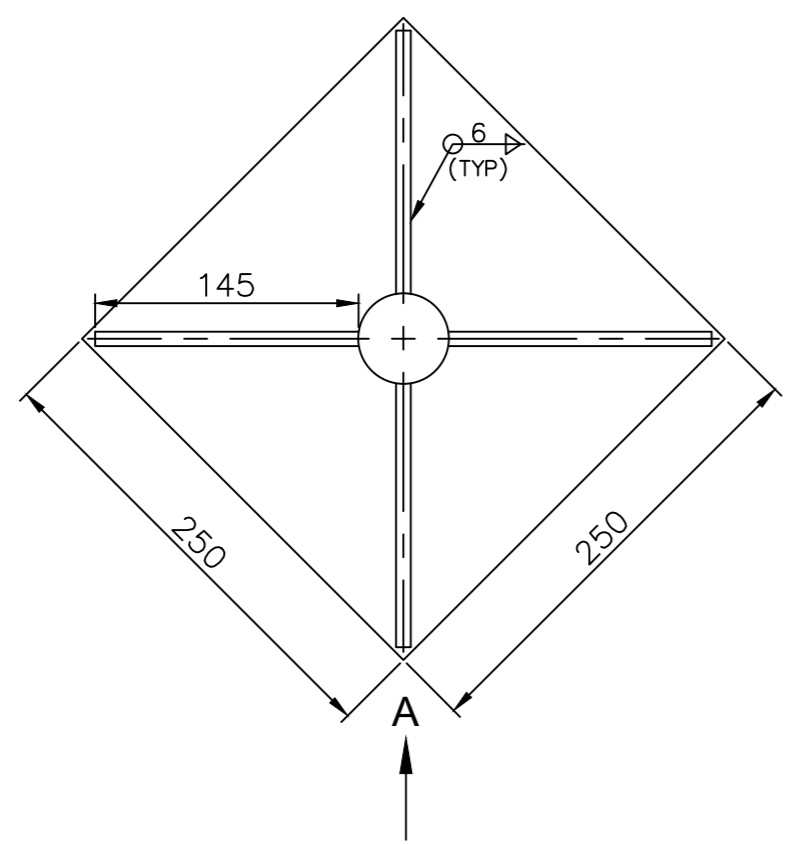

REV	DATE	ALTERED	BY	ZONE
03	01.08.2025	CHD & APPD : VSRK	MENAGA/YUVARAJ	D6
		ITEM:1 MAT. SPEC CHANGED BASED ON RCA APL/25/01 RECOMMENDATION.		

REV	DATE	ALTERED	BY	ZONE
02	24.08.23	CHD & APPD : RAJIV	MPN	E6 B4
		1) ITEM NO.03&04 MATERIAL SPEC ADDED.		
01	22.12.16	CHD & APPD : SOMU.J	MUTHU/SKP	D6
		ITEM NO.05 WEIGHT REVISED.		

CAUTION: The information on this document is the property of BHARAT HEAVY ELECTRICALS LTD. It must not be used directly or indirectly in any way detrimental to the interest of the company.

TYPE OF PRODUCT OR NAME OF CUSTOMER/PROJECT				DRN	NAME	SIGNATURE	DATE
Bharat Heavy Electricals Ltd UNIT: HIGH PRESSURE BOILER PLANT TIRUCHIRAPALLI - 620014				S.JOHN			21.04.98
				CHD	MBKRAJA		22.04.98
				APPD	R.JEYAKUMAR		22.04.98
DEPT	ST	ALL DIMENSIONS ARE IN MM	PROJECTION	SCALE	WEIGHT (Kg)	REF TO ASSY / OLD DWG	
CODE 122				N.T.S		2-35-010-01226	
TITLE						DRAWING NO :	
FOUNDATION BOLT						2-39-010-01083	
50 DIA. 2000 LONG						REV	
						03	

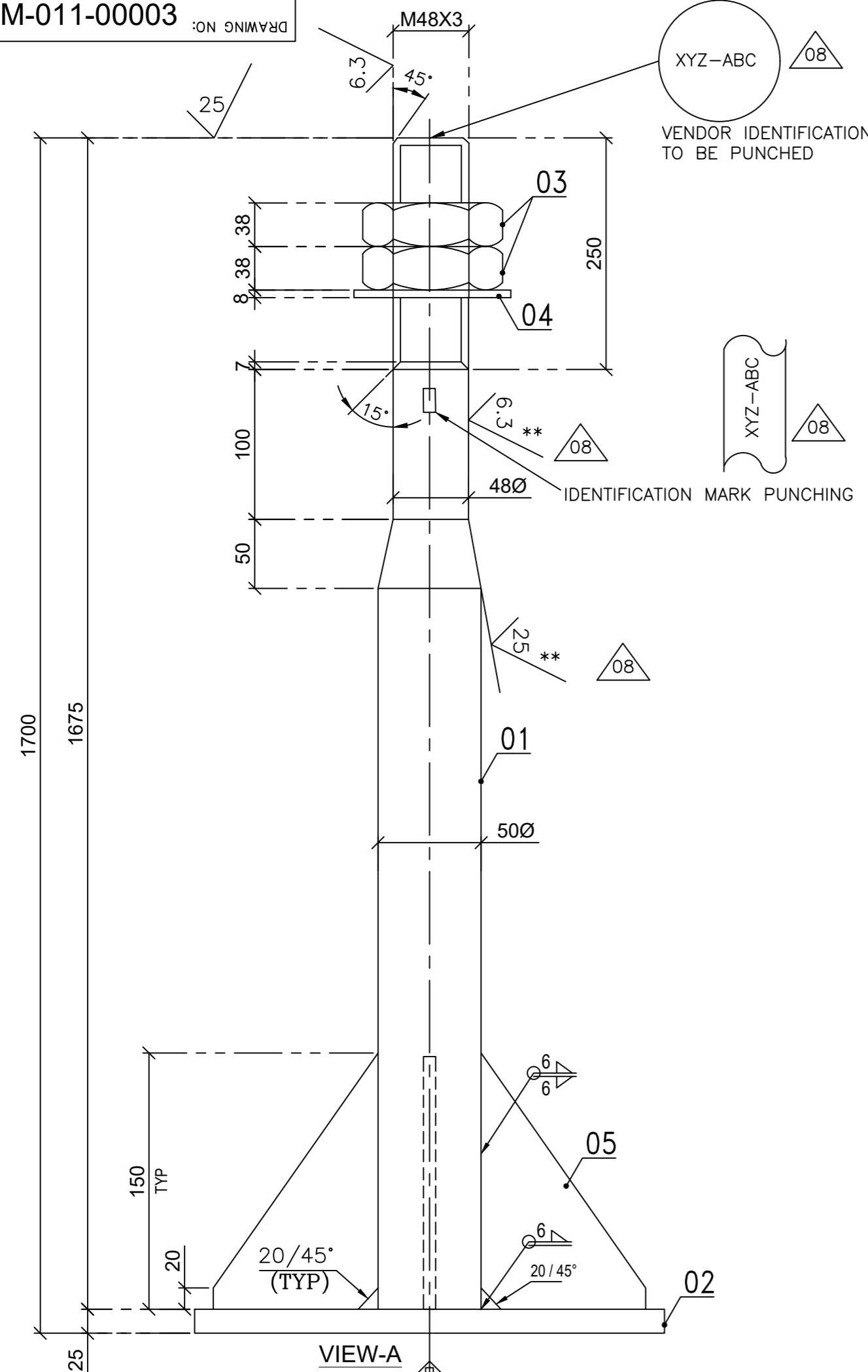

PUNCH MARK EXAMPLE:  
" M48X3 - Vendor code "

08 COMPONENT MATERIAL CODE - 940760040000

NOTES :-

- 01) FOUNDATION BOLT SHOULD NOT BE PAINTED.
- 02) THREAD ENDS OF BOLT TO BE COATED WITH RUST PROOF OIL AND PROTECTED AGAINST CORROSION .
- 03) MANUFACTURING REQUIRMENTS SHALL BE AS PER SQP NP 28/00 (LATEST REVISION).
- 04) MATERIALS AND OTHERS REQUIREMENTS ARE GIVEN PER ASSEMBLY ONLY.
- 05) DIAMETER REDUCTION (TAPERING AND REDUCED SHANK) IS TO BE BY MACHINING ONLY.
- 06) LOAD TEST REQUIREMENT - BOLT SHALL WITHSTAND MINIMUM TENSILE LOAD OF 22 MT.

SIZE AND TYPE OF WELD	TYPE OF ELECTRODE	TOTAL LENGTH OF WELD IN MTRS
6 FILLET	E 7018	1.981

VARIANT NUMBER	ITEM NUMBER	DESCRIPTION	STD	DRAWING NUMBER	ITEM NO	MATERIAL CODE	A/C/P	UNIT	UNIT WEIGHT	CS	ZONE
VAR NO						MATERIAL SPECN		DI	QUANTITY		
	05	PLATE 8 150 X 70				15011027 IS2062E250A			0.374 4		
	04	WASHER PUNCHED A48				4140800045 IS 2016			0.224 1		
	03	HEX NUT GR C M48X3				4130430048 IS11363-P3			0.870 2		
	02	PLATE 25 150X150				15011081 IS2062E250A			4.416 1		
	01	ROD DIA 50 1675				15-339-142 SA105			25.818 1		

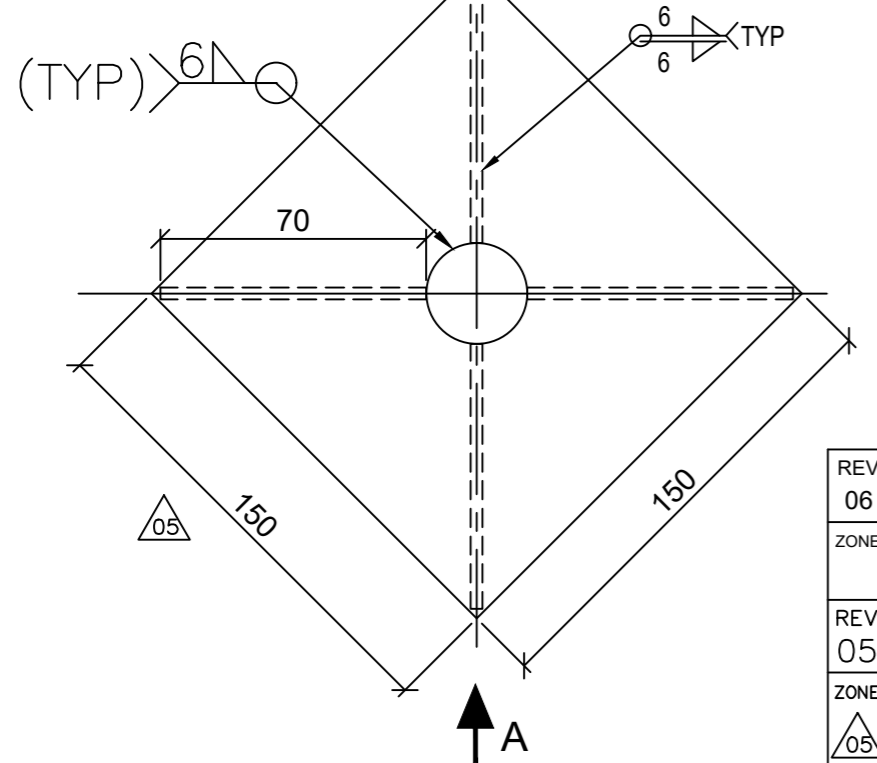

REV	DATE	ALTERED :	ZONE	REV	DATE	ALTERED :	ZONE
08	20.09.2025	K.S.PANDIAN CHD & APPD : RAJIV	08	07	26-08-2023	MPN CHD & APPD : RAJIV	07
		COMP. MCODE ADDED, NOTE 5&6 ADDED IT.NO:01 MAT. SPEC CHANGED BASED ON RCA APL/25/01 RECOMMENDATION.	08			IT. NO. 03 MATERIAL SPEC REVISED	07
06	25-08-2023	MPN CHD & APPD : RAJIV	06	04	07-09-2022	P.S.PANDIAN CHD & APPD : VSRK	04
		NOTES NO : 05 ADDED.	06			IT.NO:03 MATERIAL CODE REVISED	04
05	12.06.23	SETHUPATHI S CHD & APPD: RAJINGANDHI K	05	03	07-09-2022	P.S.PANDIAN CHD & APPD : VSRK	03
		ITEM No: 02 & 05 SIZE CORRECTED	05			IT.NO:02 QTY. REVISED	03
			05	01	25-04-2022	P.S.P/K.S.P CHD & APPD :T.HARI/VSRK	01
			05			IT.NO:01&02 MATERIAL CODE REVISED	01

CAUTION: The information on this document is the property of BHARAT HEAVY ELECTRICALS LTD. It must not be used directly or indirectly in any way detrimental to the interest of the company.

TYPE OF PRODUCT OR NAME OF CUSTOMER/PROJECT

**Bharat Heavy Electricals Ltd**  
UNIT: HIGH PRESSURE BOILER PLANT  
TIRUCHIRAPALLI - 620014

DRN	K.S.PANDIAN	SIGNATURE	DATE
CHD	T.HARI		23-12-2021
APPD	VSRK		24-12-2021

DEPT ST  
CODE 122

ALL DIMENSIONS ARE IN MM

PROJECTION

SCALE N.T.S

WEIGHT (Kg) 33.694

REF TO ASSY / OLD DWG

TITLE **FOUNDATION BOLT 50 DIA-1700 LONG**

DRAWING NO : **2-FM-011-00003**

REV **08**

DRAWING NO. 2-FM-011-00010

FOR TOLERANCES OF UNTOLERANCED DIMENSIONS DURING MANUFACTURE REFER PLANT STD. NO TP 023 0299

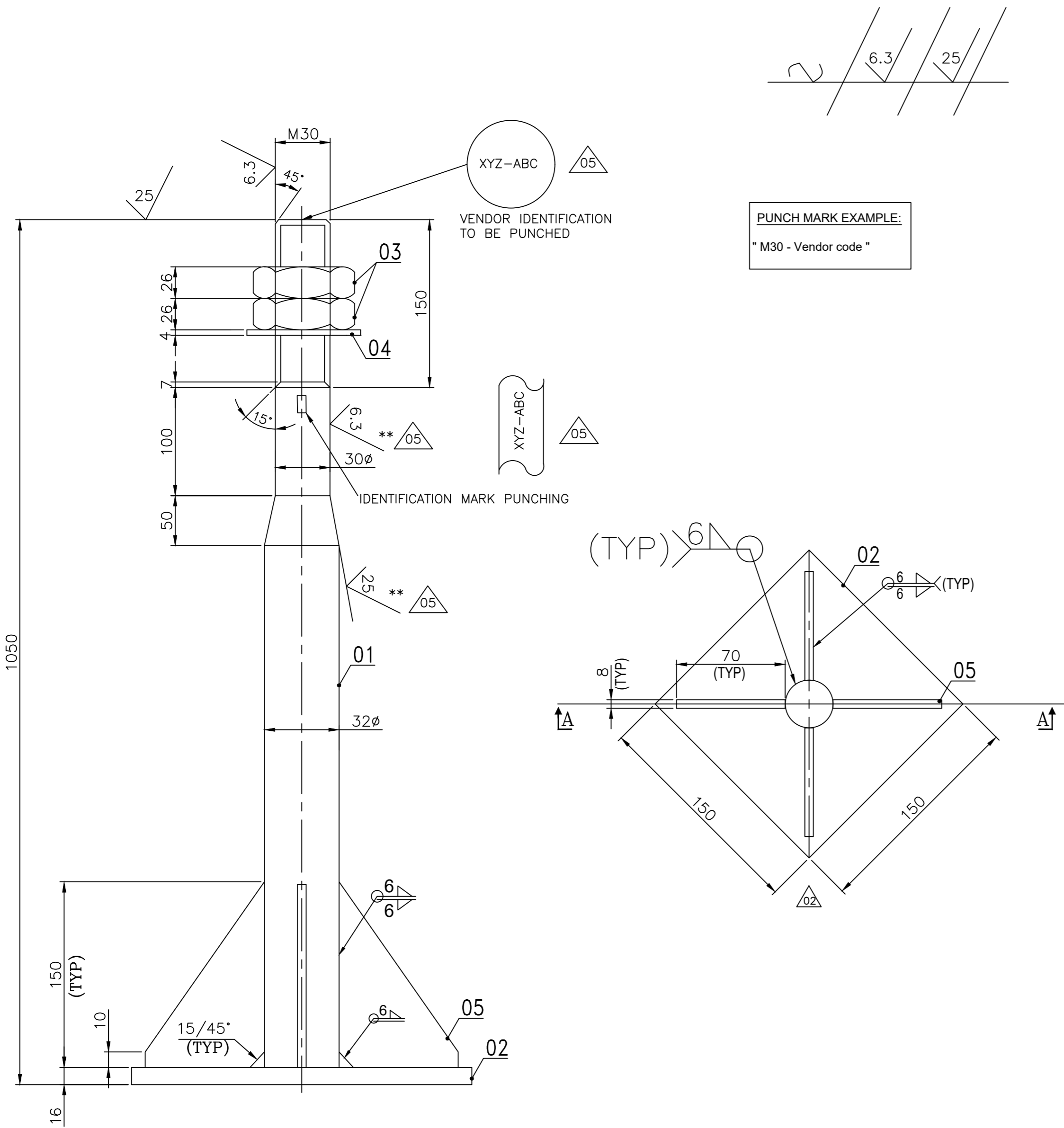

SIZE AND TYPE OF WELD	TYPE OF ELECTRODE	TOTAL LENGTH OF WELD IN MTRS
6 FILLET	E 7018	1.924

COMPONENT MATERIAL CODE - 940760030000

**NOTES :-**

- 01) FOUNDATION BOLT SHOULD NOT BE PAINTED.
- 02) THREAD ENDS OF BOLT TO BE COATED WITH RUST PROOF OIL AND PROTECTED AGAINST CORROSION .
- 03) MANUFACTURING REQUIRMENTS SHALL BE AS PER SQP NP 28/00 (LATEST REVISION).
- 04) MATERIALS AND OTHERS REQUIREMENTS ARE GIVEN PER ASSEMBLY ONLY.
- \*\* 05) DIAMETER REDUCTION (TAPERING AND REDUCED SHANK) IS TO BE BY MACHINING ONLY.
- 06) LOAD TEST REQUIREMENT - BOLT SHALL WITHSTAND MINIMUM TENSILE LOAD OF 8 MT.

VARIANT NUMBER	ITEM NUMBER	DESCRIPTION	STD	DRAWING NUMBER	ITEM NO	MATERIAL CODE	A/C/P	UNIT	UNIT WEIGHT	CS	ZONE
VAR NO						MATERIAL SPECN		DI	QUANTITY		
05	05	PLATE 8 70 X 150				15011027 IS2062E250A	No		0.374 4		
04	04	WASHER PUNCHED A33				41408000030 IS 2016	No		0.050 1		
03	03	HEX NUT GR C M30				41304000030 IS1363-P3	No		0.231 2		
02	02	PLATE 16 150X150				15011026 IS2062E250A	No		2.826 1		
01	01	ROD DIA 32 1034				15-339-140 SA 105	No		6.520 1		

SECTION-AA

REV	DATE	ALTERED	ZONE	REV	DATE	ALTERED	ZONE
04	26.08.23	CHD & APPD : RAJVGANDHI K	04	02	12.06.23	CHD & APPD : RAJVGANDHI K	02
03	24.08.23	CHD & APPD : RAJIV	03	01	07.07.2022	CHD & APPD : MPN & RAJIV	01
05	04.10.2025	CHD & APPD : RAJIV	05	03	24.08.23	CHD & APPD : RAJIV	03

CAUTION: The information on this document is the property of BHARAT HEAVY ELECTRICALS LTD. It must not be used directly or indirectly in any way detrimental to the interest of the company.

TYPE OF PRODUCT OR NAME OF CUSTOMER/PROJECT

Bharat Heavy Electricals Ltd  
UNIT: HIGH PRESSURE BOILER PLANT  
TIRUCHIRAPALLI - 620014

DRN	NAME	SIGNATURE	DATE
CHD	SETHUPATHI S		05.02.2022
APPD	PADMANABAN M		05.02.2022
	RAJIVGANDHI K		05.02.2022

DEPT: ST, CODE: 122, ALL DIMENSIONS ARE IN MM, PROJECTION: N.T.S, SCALE: N.T.S, WEIGHT (Kg): 11.354

TITLE: FOUNDATION BOLT 32 DIA. 1050 LONG

DRAWING NO: 2-FM-011-00010

REV: 05